

Conveyor Belt - Material Flow Detector

Model: IS-MFL



OVERVIEWS

Material flow detector is a device to detect whether there is material in belt conveyor. Connect the cable to the main control room, and the staff can observe the material feeding status through the indicator light. This product can also be used together with automatic sprinkler to realize the function of automatic sprinkling when there is material. Staff can take corresponding measures according to different situations of conveyor operation

CHARACTERISTIC

- Adopt high-strength A-alloy precise die-casting shell, with strong impact resistant capability
- The shell has high protection level, good sealing, and can be used in harsh environment
- Large contact capacity, sensitive action and reliable performance

TECHNICAL DATA

Ambient temperature	-40°C~ 50°C	Initial position	Touch the lower surface of the upper conveyor belt with the trolley wheel
Relative humidity	0 ~ 95%		
Atmospheric pressure	80 kPa ~110kPa		
Output mode and quantity	SPDT	Action angle	20°±2°
Contact rating	AC380V 3A - DC24V 3A	Limit angle	75°
Reset mode	Automatic	Protection level	IP67

DIMENSION

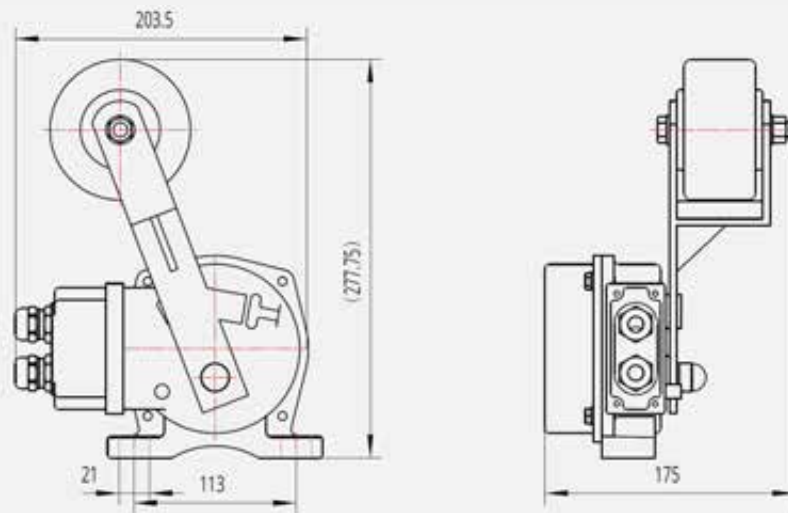

Units : mm

INSTALLATION DIAGRAM

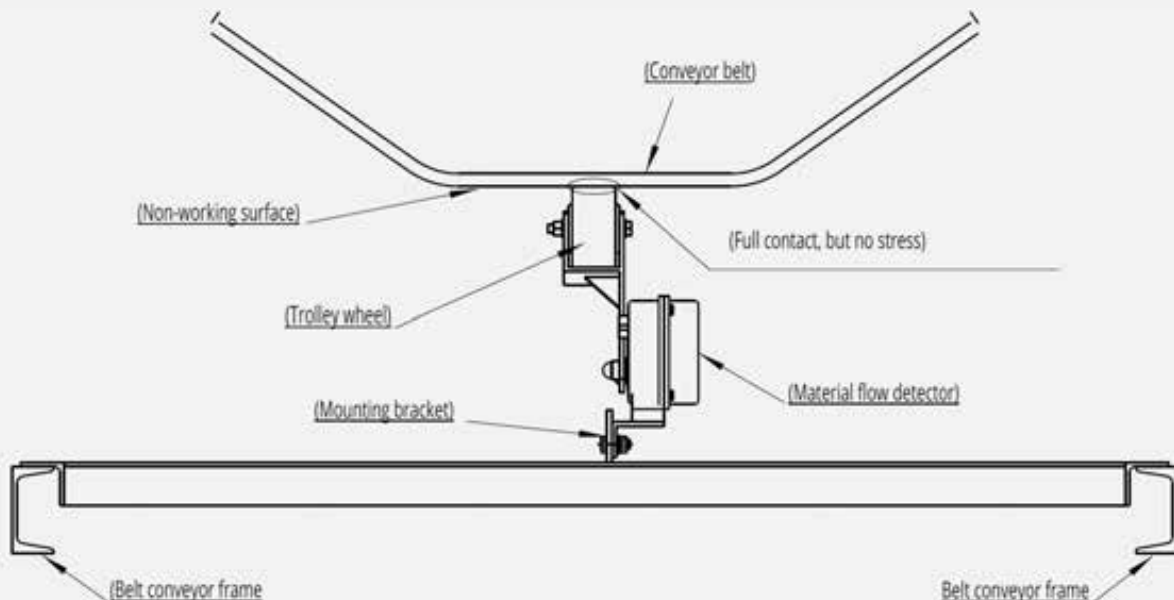

Mounting bracket

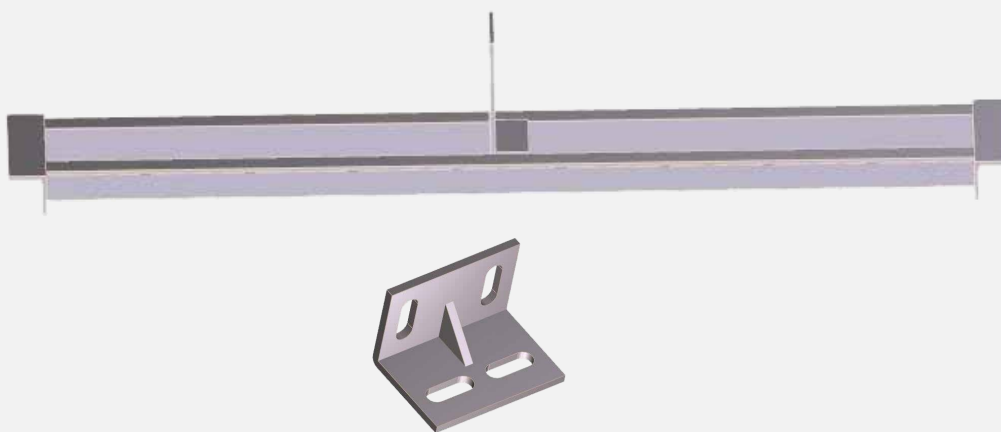

INSTALLATION STEPS

- 1) Install the mounting bracket on the longitudinal beam of the conveyor, and fix the material flow detector on the bracket with bolts, and fix it after the position is determined

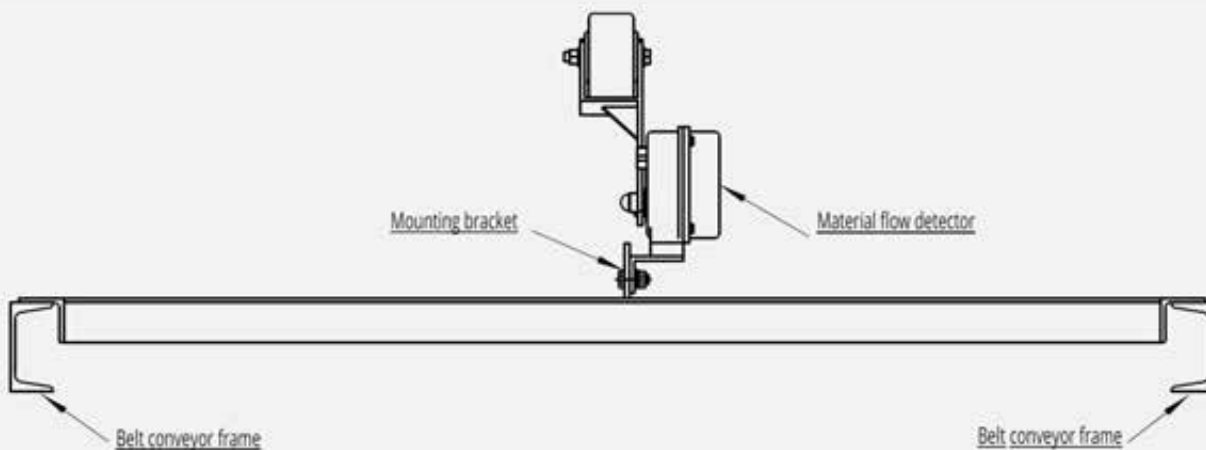

- 2) The product shall be installed at a location with a large amount of material sinking, preferably in the middle between the two idlers, and the detector shall be installed on the non-working surface (lower surface) of the upper conveyor belt. When there is no material, the trolley wheel should be in full contact with the non-working surface (lower surface) of the conveyor belt, but it cannot be stressed, tighten the bolt after adjusting the position

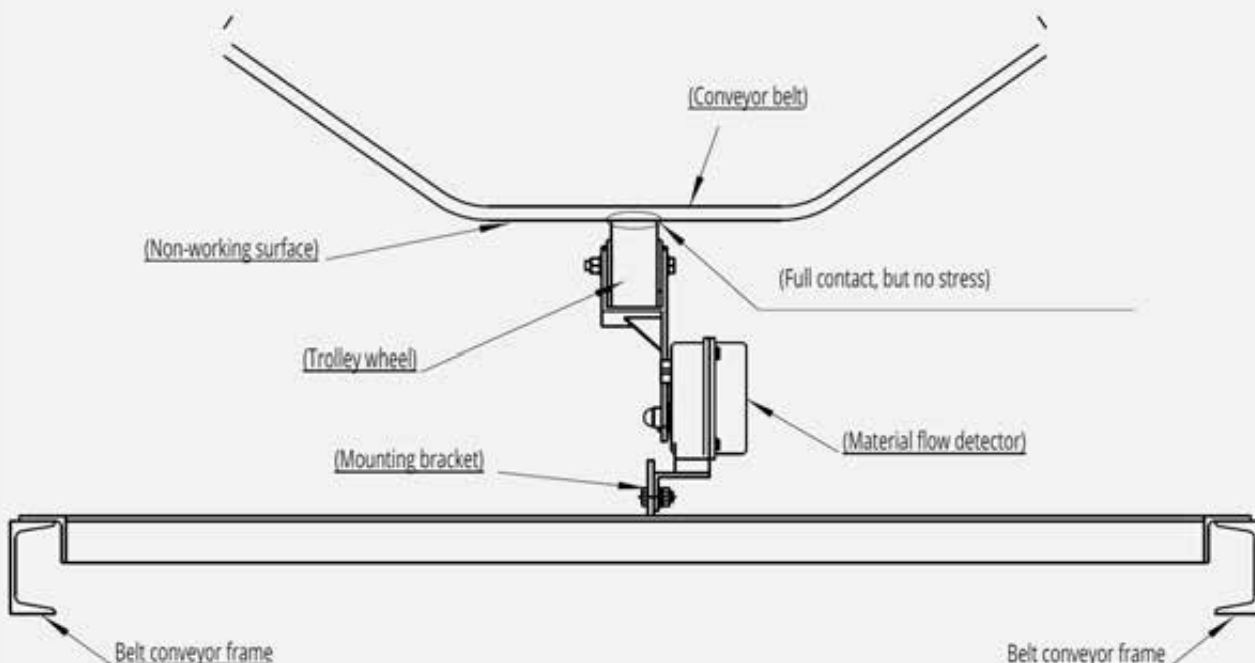

WIRING DIAGRAM

Detector built-in wiring cavity, open the side cover, have a row of 6P wiring terminals, wiring terminals marked with schematic diagram, as shown in the figure, if there is any exception, please refer to the circuit diagram on the switch

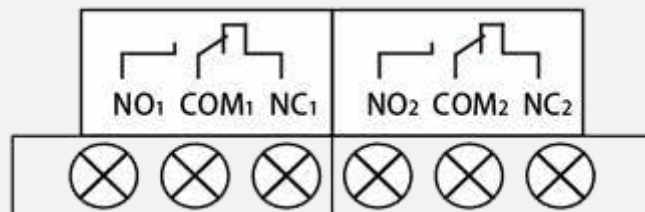

WORKING PRINCIPLE

This product adopts Load type detect. When there is material on the conveyor belt, the conveyor belt will sink accordingly due to the weight of materials. When the conveyor belt sinks, the detector's trolley wheel will be pressed down, through the internal transmission mechanism of the device to make the position switch action, send out signals, to achieve the detection function

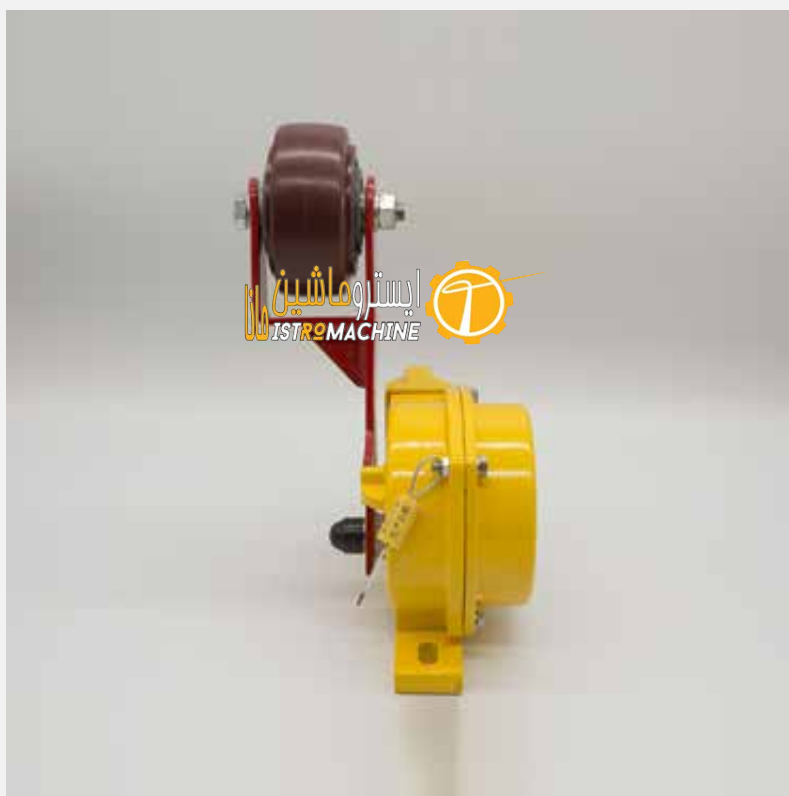

Conveyor Belt - Material Flow Detector

Model: IS-MFB



OVERVIEWS

Material flow detector is a device to detect whether there is material in belt conveyor. Connect the cable to the main control room, and the staff can observe the material feeding status through the indicator light. This product can also be used together with automatic sprinkler to realize the function of automatic sprinkling when there is material. Staff can take corresponding measures according to different situations of conveyor operation

CHARACTERISTIC

- Adopt high-strength A-alloy precise die-casting shell, with strong impact resistant capability
- The shell has high protection level, good sealing, and can be used in harsh environment
- Large contact capacity, sensitive action and reliable performance
- With waterproof wiring cavity, wiring is convenient

TECHNICAL DATA

Ambient temperature	-40°C~ 50°C	Initial position	Touch the lower surface of the upper conveyor belt with the trolley wheel
Relative humidity	0 ~ 95%		
Atmospheric pressure	80 kPa ~110kPa		
Output mode and quantity	SPDT	Action angle	20°±2°
Contact rating	AC380V 3A - DC24V 3A	Limit angle	75°
Reset mode	Automatic	Protection level	IP67

DIMENSION

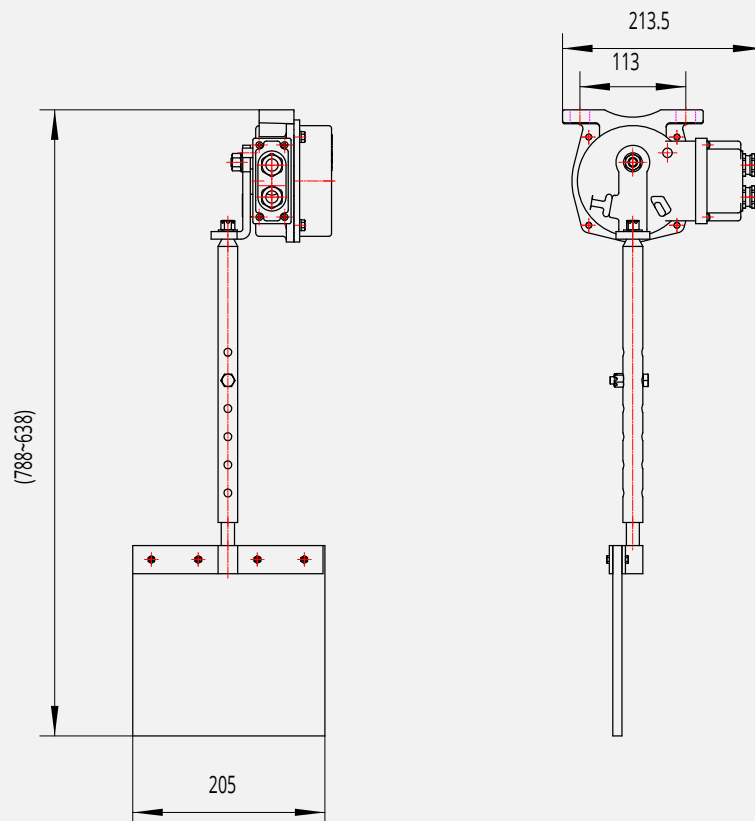

Units : mm

INSTALLATION DIAGRAM

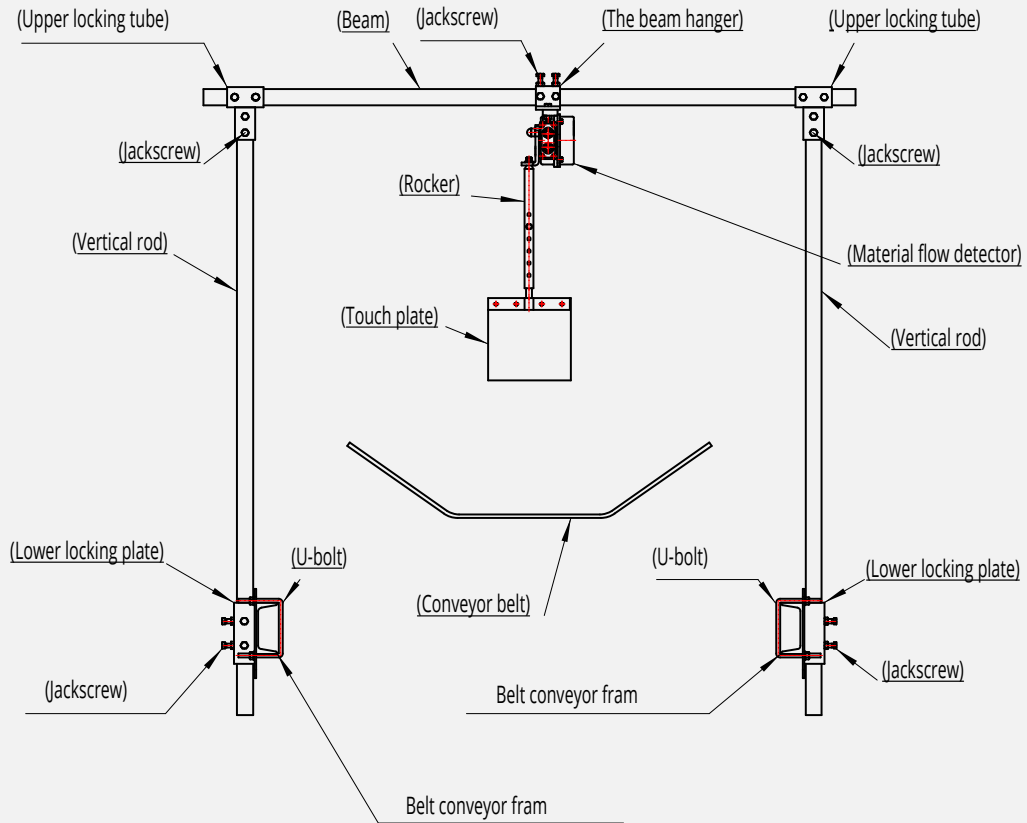

ACCESSORIES

Vertical rod



Beam



Contact plate



Beam hanger

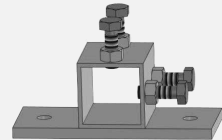

U-bolt



The locking plate

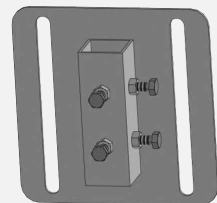

1) Assemble the material flow detector as shown in the figure

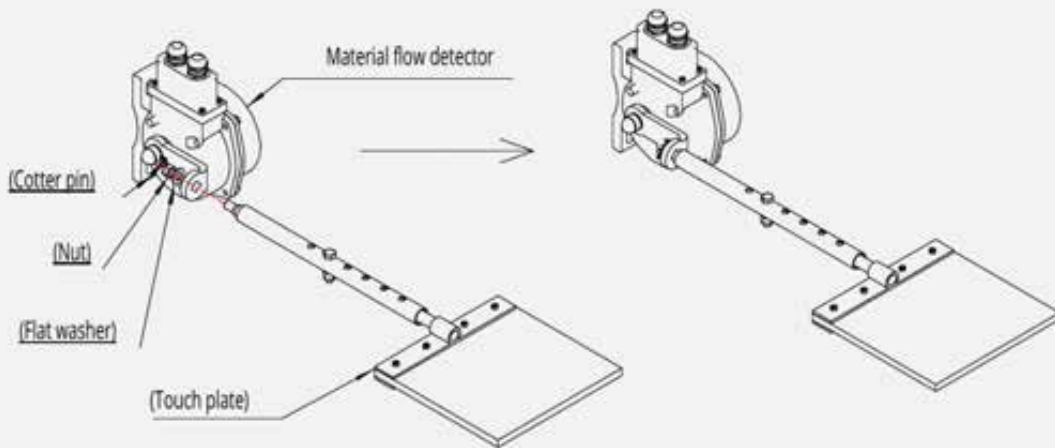

2) Users shall choose different installation positions according to different uses. It should be installed near the chute outlet of belt conveyor when it is used to detect the instantaneous state of material. As a worker safety protection device, it should be installed in the middle or back of the belt conveyor

3) After the installation position is determined, according to the installation diagram, fix the locking plates on the longitudinal beam of the belt conveyor with U-bolts

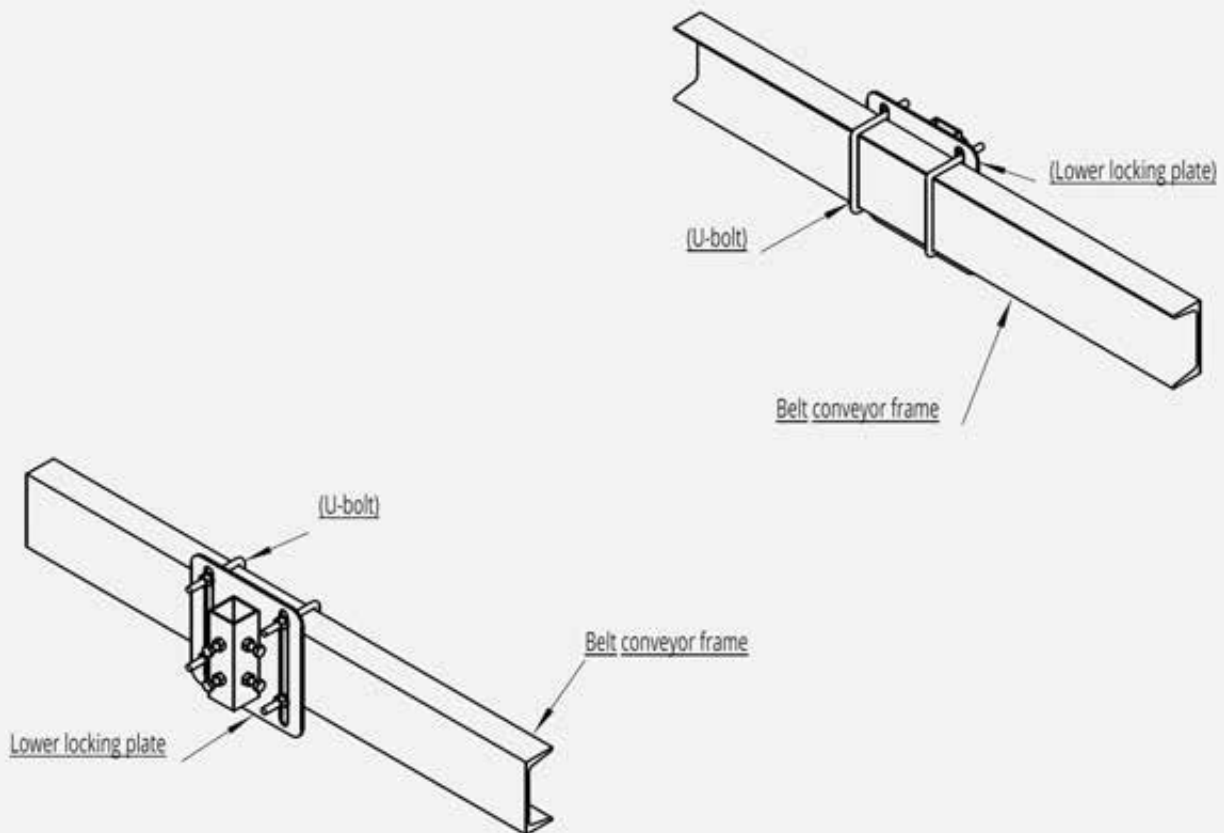

4) String the left and right vertical rod into the lower locking plate, and install the beam hanger and beam on the vertical rod as shown in the figure

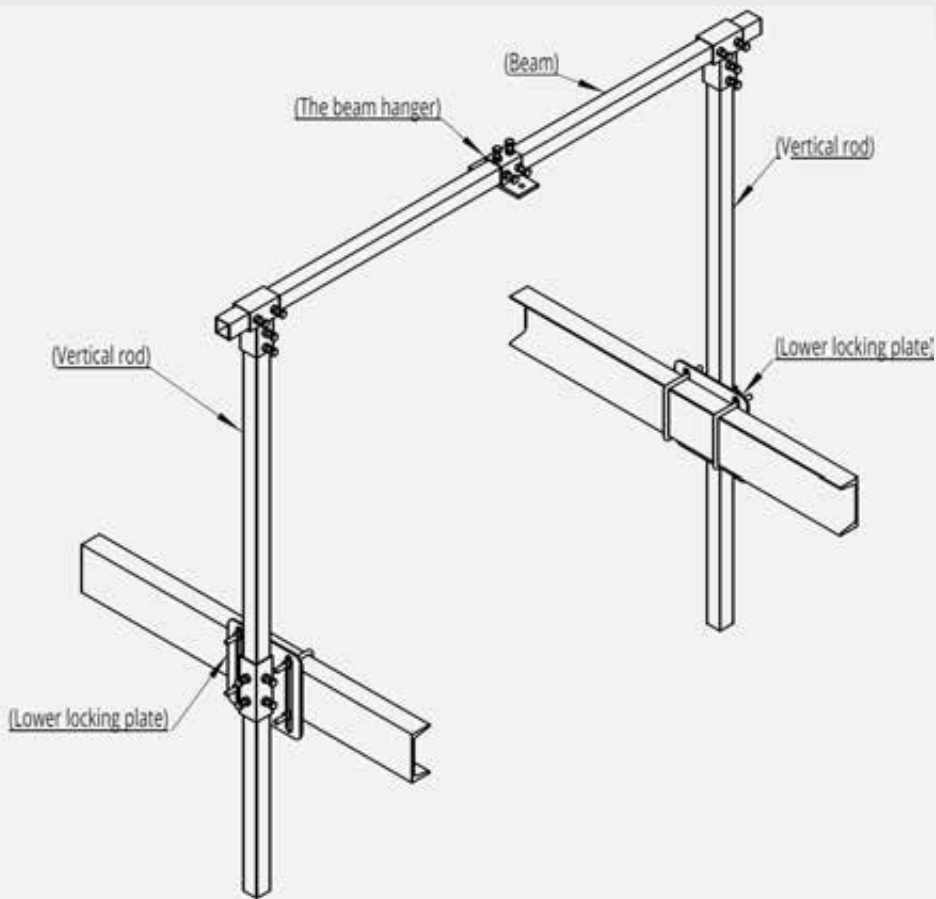

- 5) Install the material flow detector on the beam hanger with fasteners. Note that the detector moves in the same direction as the operation of the upper conveyor belt. Adjust the position of the detector contact plate to the middle of the belt. Lock the upper locking tube and the jackscrew of the beam hanger

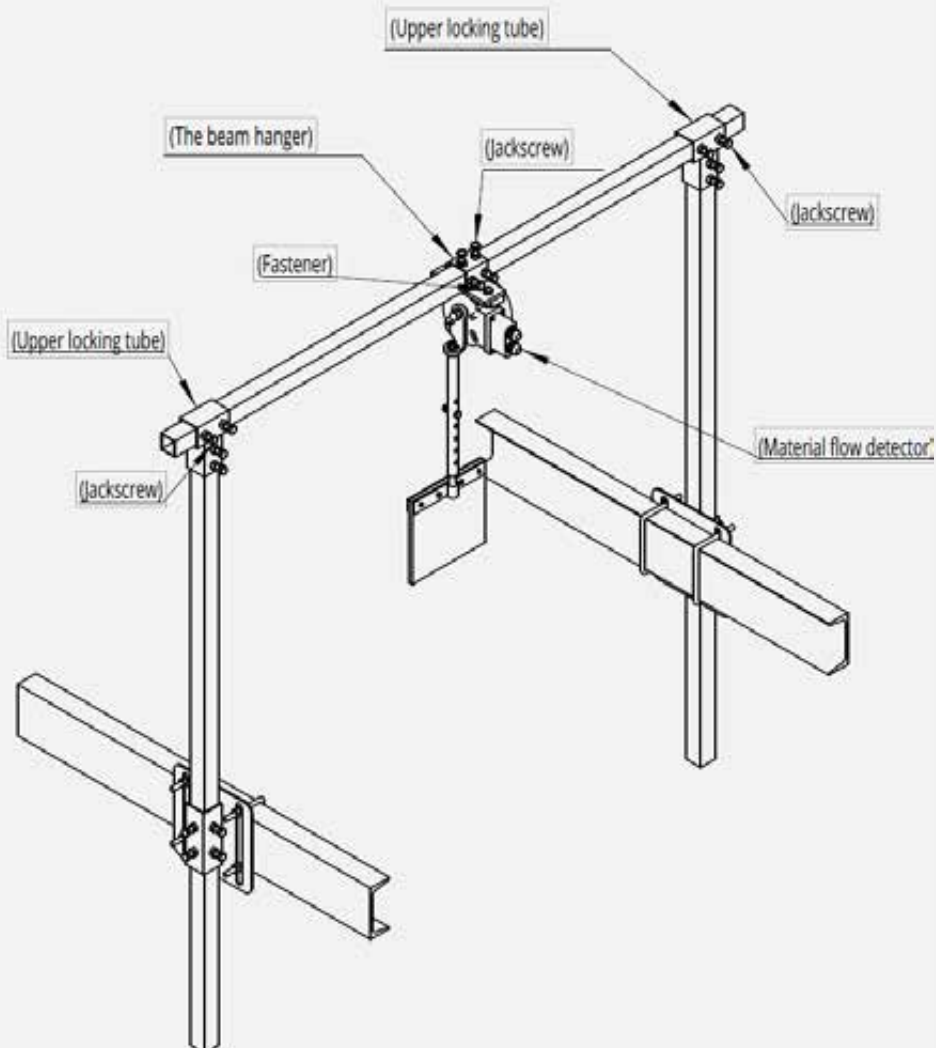

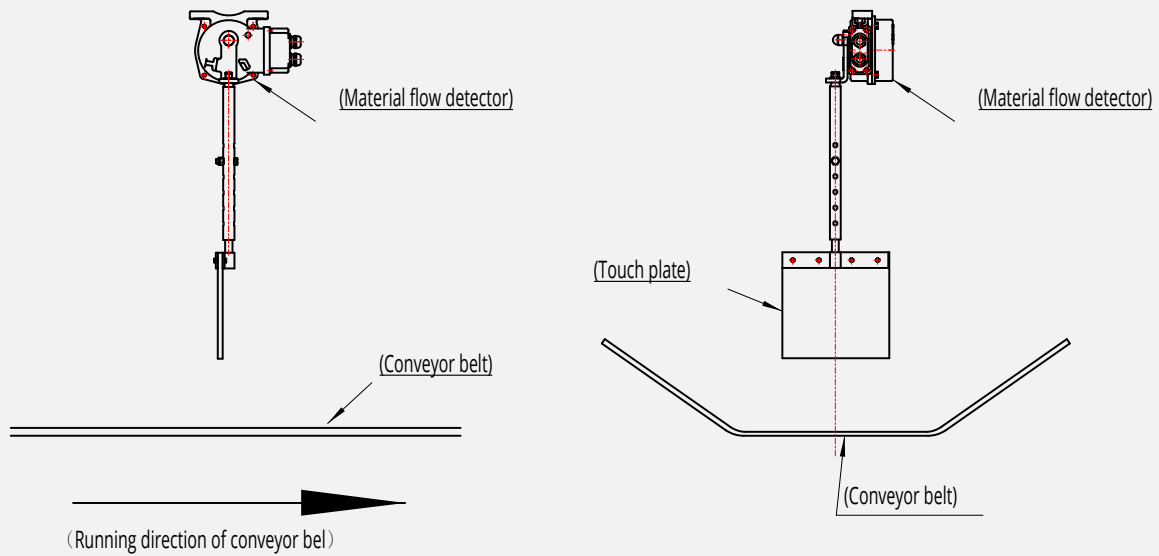

6) Adjust the distance between the contact plate and the conveyor belt surface by moving the vertical rod up and down according to the height of materials that conveyor transport, and lock the jackscrew on the lower locking plate when the distance is appropriate. When the height needs to be adjusted later, loosen the fastener on the detector rocking bar for adjustment. When the detector is used as a protective device, please adjust the height of the contact plate to ensure that it does not touch the contact plate during material transfer, avoid false alarm

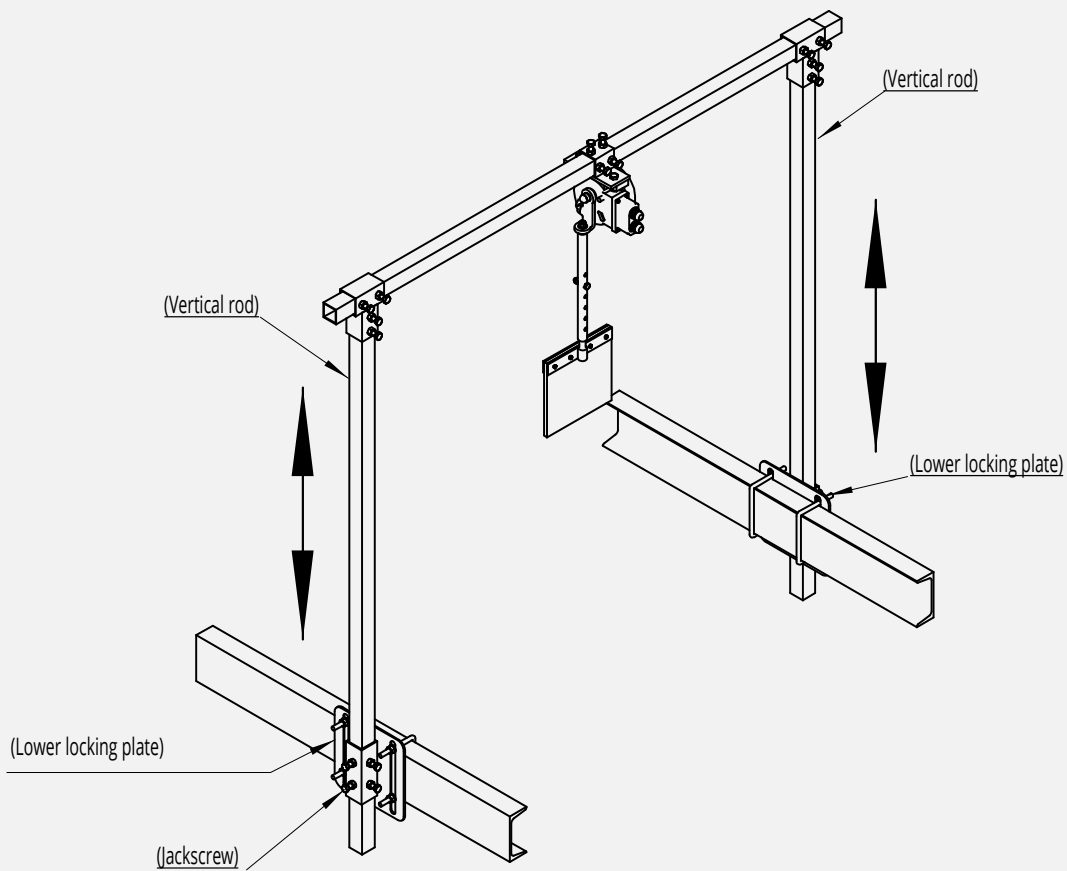

WIRING DIAGRAM

The detector has built-in wiring cavity. Open the side cover, have a row of 6P wiring terminals. Wiring terminals are marked with schematic diagram. If there is any exception, please refer to the circuit diagram on the switch

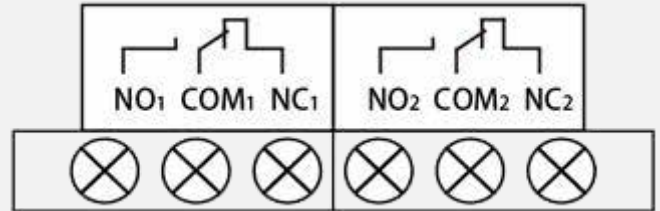

WORKING PRINCIPLE

When the conveyor runs without material, the contact plate is in a static state and perpendicular to the conveyor belt surface. When the conveyor belt runs with material, the contact plate is pushed by materials and deflected, when the deflection angle is more than 20°, the detector send out signal to realize the detection function

