

Conveyor Belt - Longitudinal belt tear detector

Model: IS-BTD-B



OVERVIEWS

When the conveyor belt occurs longitudinal tear, foreign body puncture, junction damage in operation, Belt tear detector can send alarm or emergency stop signal timely through sensor detection, avoid the expansion of the accident. W

CHARACTERISTIC

- Single control box connected with more than one sensor, suitable for long conveyor use.
- It has input signal delay de-jitter function, avoid disoperation.
- With manual self-test function, high reliability.
- Relay output, large contact capacity.
- Sensor is a fully enclosed structure of conductive rubber, and can be used in harsh environment.

TECHNICAL DATA

Ambient temperature	-10°C~50°C	Contact rating	DC24V-AC380V 5A
Relative humidity	0 ~ 95%	Rated power	5W
Atmospheric pressure	80 kPa ~110kPa	Input signal de-jitter range	0~9S
Electrical life	>100,000 times	Protection level	IP65
Output mode and quantity	1×DPDT		

Structure features and main dimensions

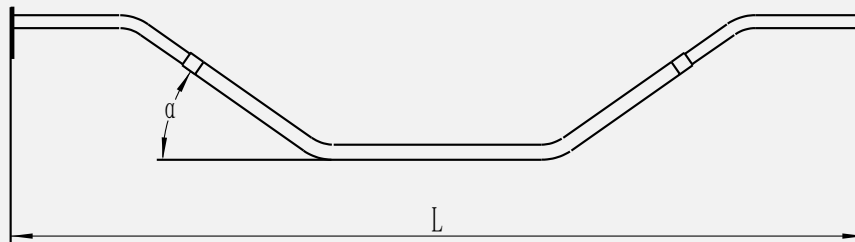

Sensor size figure

B	L	α				
		0°	30°	35°	40°	45°
650	950	0°	30°	35°	40°	45°
800	1150	0°	30°	35°	40°	45°
1000	1350	0°	30°	35°	40°	45°
1200	1600	0°	30°	35°	40°	45°
1400	1800	0°	30°	35°	40°	45°
1600	2050	0°	30°	35°	40°	45°
1800	2240	0°	30°	35°	40°	45°
2000	2480	0°	30°	35°	40°	45°

Sensor size table

B: Belt width L: Length α: Angle

B \ N	1	2	3	4	5
650	XLZL-B-650/1	XLZL-B-650/2	XLZL-B-650/3	XLZL-B-650/4	
800	XLZL-B-800/1	XLZL-B-800/2	XLZL-B-800/3	XLZL-B-800/4	
1000	XLZL-B-1000/1	XLZL-B-1000/2	XLZL-B-1000/3	XLZL-B-1000/4	
1200	XLZL-B-1200/1	XLZL-B-1200/2	XLZL-B-1200/3	XLZL-B-1200/4	
1400	XLZL-B-1400/1	XLZL-B-1400/2	XLZL-B-1400/3	XLZL-B-1400/4	
1600	XLZL-B-1600/1	XLZL-B-1600/2	XLZL-B-1600/3	XLZL-B-1600/4	
1800	XLZL-B-1800/1	XLZL-B-1800/2	XLZL-B-1800/3	XLZL-B-1800/4	XLZL-B-1800/5
2000	XLZL-B-2000/1	XLZL-B-2000/2	XLZL-B-2000/3	XLZL-B-2000/4	
2200	XLZL-B-2200/1	XLZL-B-2200/2	XLZL-B-2200/3	XLZL-B-2200/4	

Belt tear detector model list

B: Belt width N: quantity of single controller connected sensor

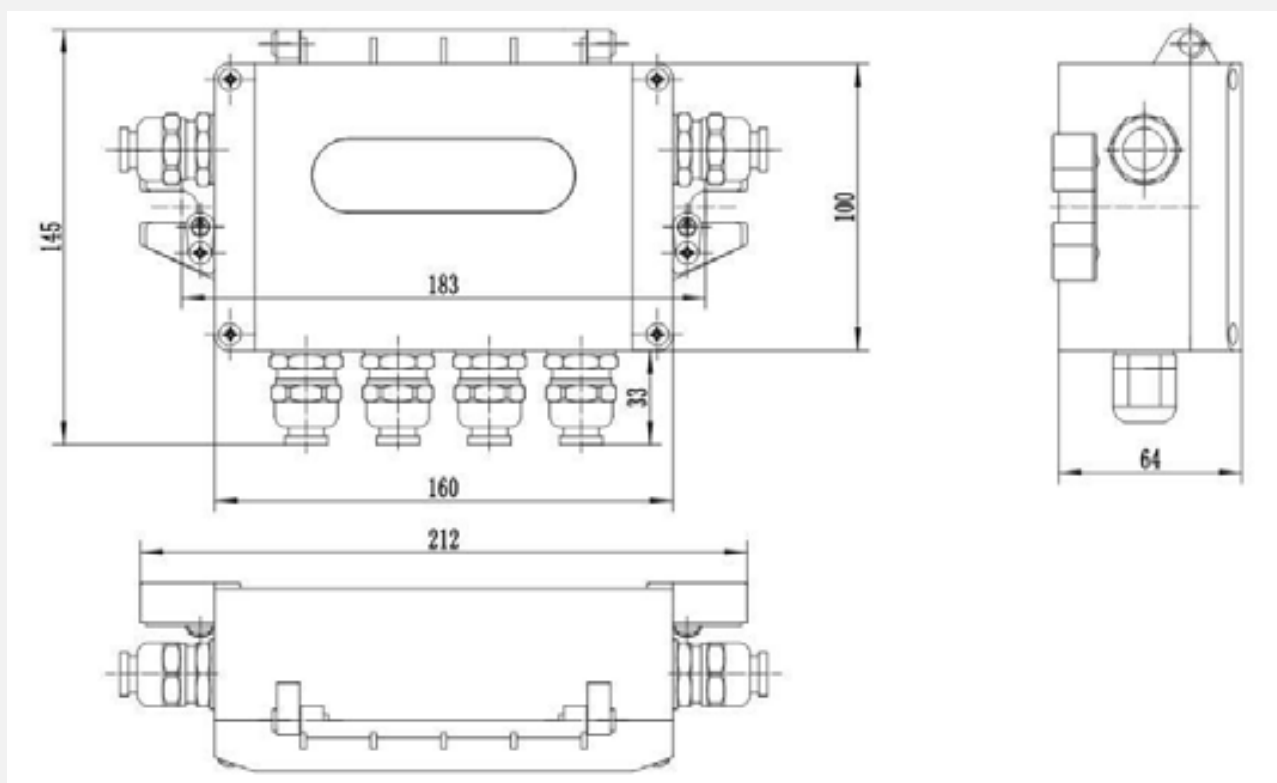

Appearance size chart Units: mm

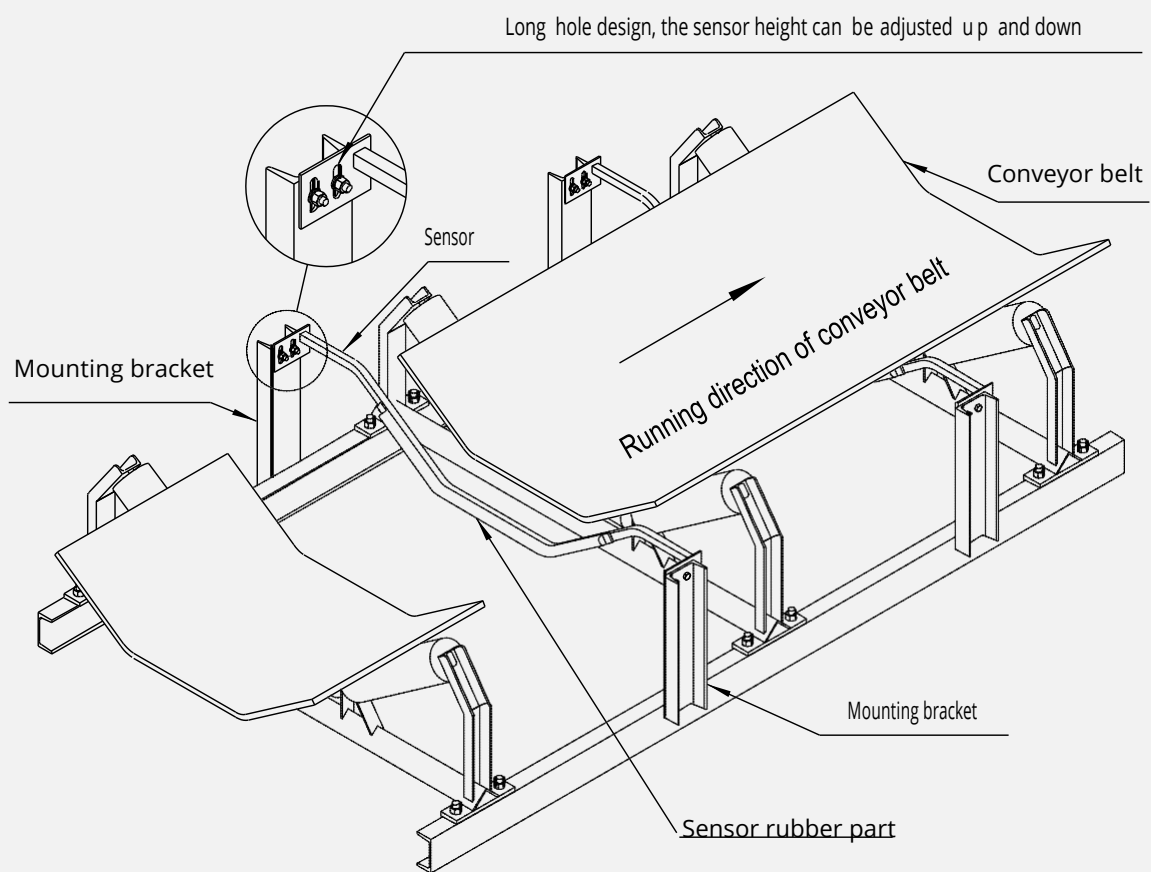
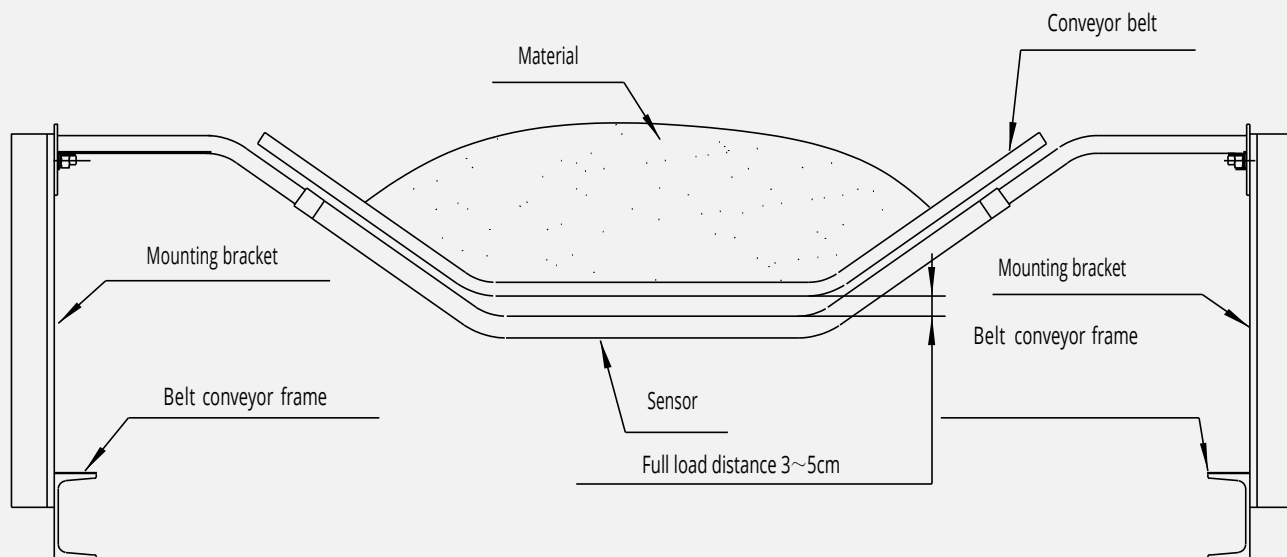

Installation indication diagram

ACCESSORIES

Mounting bracket



Controller mounting bracket



Controller



INSTALLATION STEPS

- 1) Install the sensor on blanking port under the conveyor belt between two set idler group. Before installation, hand-held sensor and mounting bracket detect the install height, and the relative position of sensor mounting bracket and conveyor frame is marked, welding the sensor mounting bracket and the conveyor frame, in order to avoid inappropriate installation position, first only weld two points

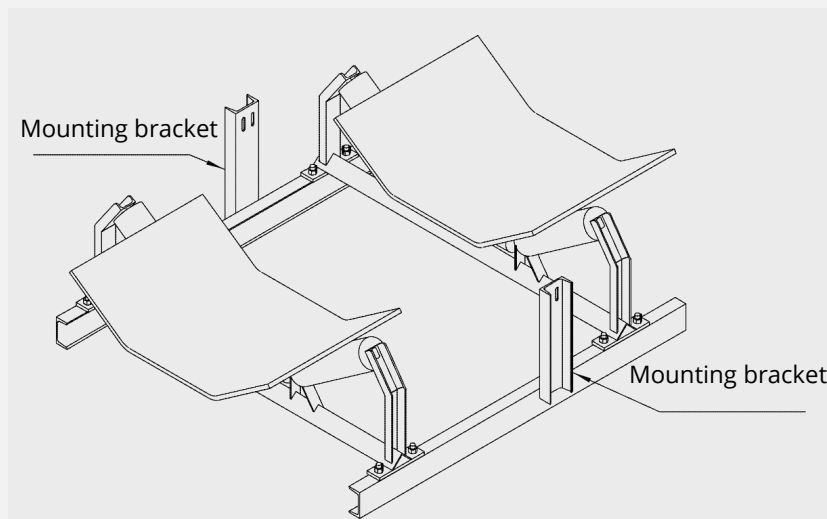

- 2) According to the installation diagram, fix the sensor on the sensor mounting bracket with bolts. The direction of the rubber part of the sensor must be correct (the rubber side faces the tail of the conveyor). and the bolts don't need tighten. At this time, the distance between the sensor and the upper conveyor belt can be slightly larger. When the conveyor is full load, the height of the sensor can be adjusted so that the distance between the sensor and the upper conveyor belt is 3 to 5 cm

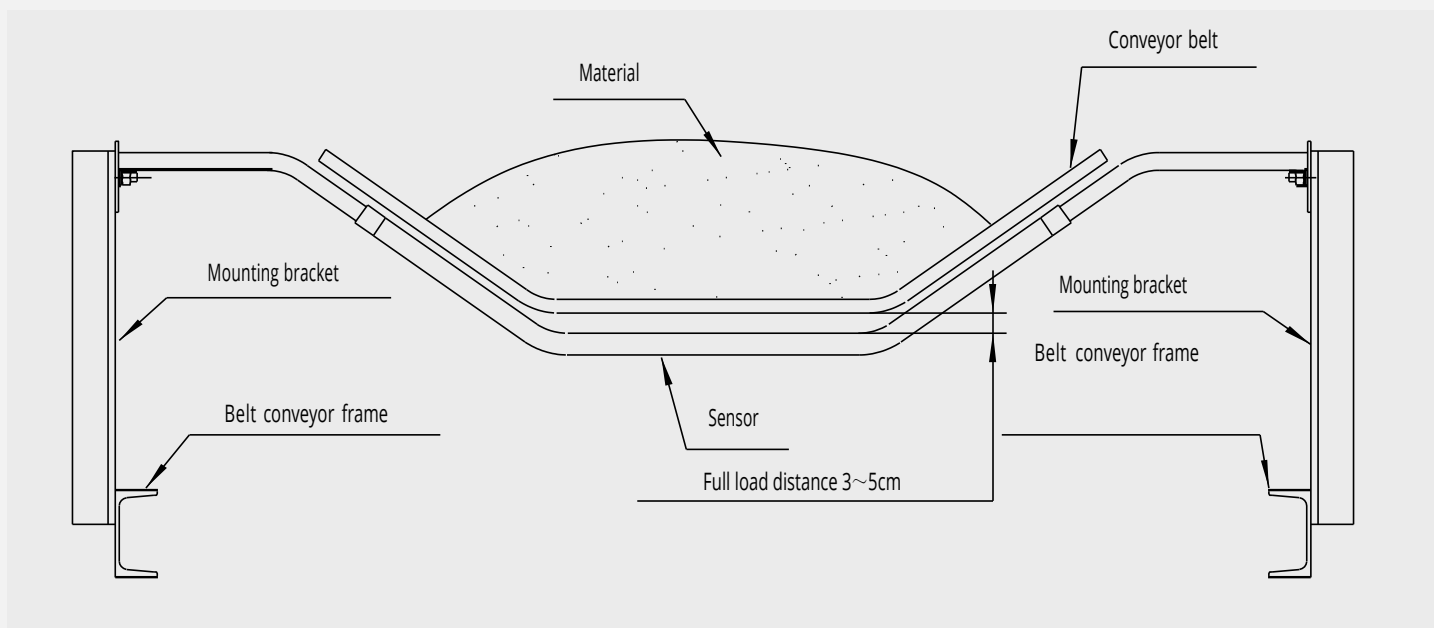

3) After adjustment, the sensor mounting bracket and the conveyor frame are welded firmly, and tighten the fixed bolt of the sensor. If the conveyor belt below the blanking port is equipped with multiple idler groups (or impact bed), and the spacing is very small, there is no suitable position to install the sensor, the sensor can be installed in the position shown in the figure

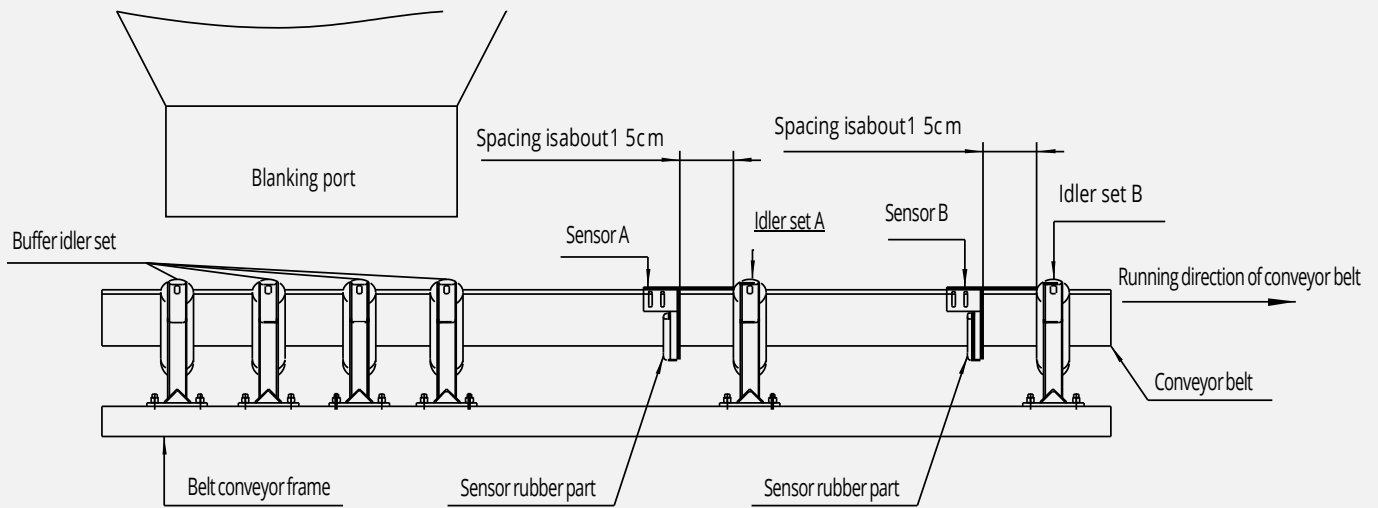

(4) Install controller on the conveyor frame near the sensor (or on the wall) where it is easy to observe and operated

WIRING METHOD

Open the controller, have a row of terminals and wiring diagram. The controller can output two sets of switching simultaneously (alarm 1 and alarm 2). Two sets of action are consistent, it can be measured by a multimeter. Between two sensors is in parallel connect. The output line of each sensor is two core wires, regardless of positive or negative, and it is connected to the "signal input" of the terminal in the control box. If the output line of the sensor is not long enough, the signal line can be extended. When the extension line is $2 \times 0.5 \text{ mm}^2$ with multiple soft copper wires, the length is recommended to be less than 50 meters. The wiring diagram is shown in the figure

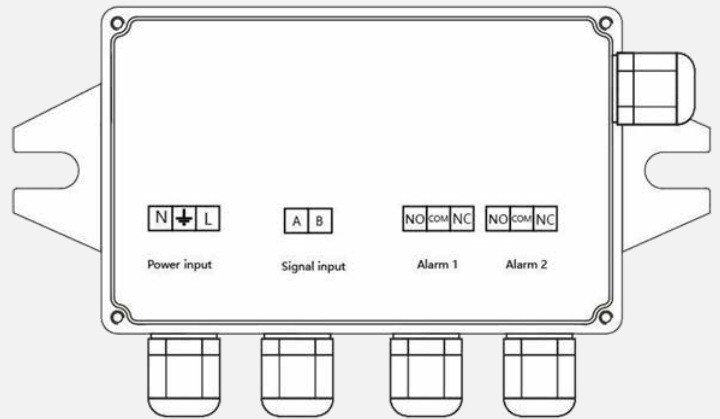

Panel indication :

- Selection key: Setting alarm reset mode
- Reset key: Alarm reset (reset mode is valid when manual)
- Delay key: Set alarm action delay time (0-9 seconds)

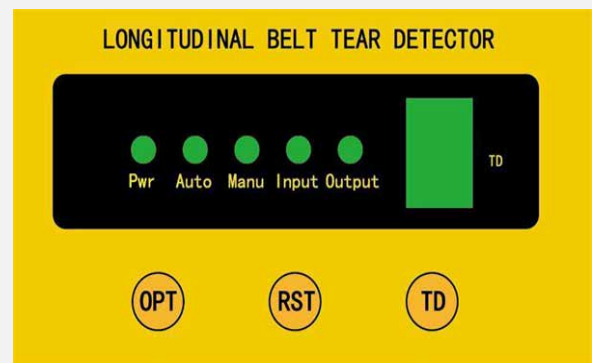

WORKING PRINCIPLE

The sensor adopts advanced conductive rubber technology, which is an intrinsically safe product. When the conveyor belt is punctured by materials or sharp foreign bodies, it squeezes the sensor while running with the conveyor belt, thus sending a signal to the controller

The controller adopts electronic circuit and is equipped with self-locking and time-delay alarm functions. The controller panel is equipped with a tear alarm lamp. When the conveyor belt is torn, the controller receives the signal from the sensor and sends out the alarm and stop signal through the electronic circuit

The device is suitable for belt conveyors of different specifications. A controller can be used with multiple sensors (between two sensors is in parallel connect), and the conveyor belt need not be processed when installed. The number of sensor should be determined by the user according to the actual needs