



## Belt Bucket Elevator Misalignment Switch

---

Model: IS-HDS2



## OVERVIEWS

in conveyor systems with belt bucket elevators, material overflow or malfunctions may cause belt misalignment and major damage. Istromachine bucket elevator monitoring devices are used to detect and switch off misaligned belt bucket elevators. When the belt conveyor, zipper, scraper, elevator and other transmission machinery have running deviation, dislocation and other faults, it can timely send alarm signal to the microcomputer control system or stop the machine directly, effectively protect the equipment and personal safety, avoid the expansion of accidents and achieve the purpose of protecting

production and equipment. In addition, because the signal can be sent to the microcomputer control system, it is convenient to realize the automatic control of the factory, so as to achieve the purpose of reducing staff, increasing efficiency and centralized control, which is conducive to production and scheduling. It is widely used in steel, electric power, chemical industry, cement, coal, metallurgy, building materials, mines, ports and wharves, grain, warehouse and other transport equipment industries.

## CHARACTERISTIC

- Adopt high-strength Aluminum-alloy precise die-casting shell, with strong impact resistant capability
- High protective degree of shell, good sealing property.
- double switching output, large contact capacity, sensitive action and reliable performance.

## TECHNICAL DATA

Ambient temperature	-30°C~ +60°C	Action force	50N
Relative humidity	< 90%	Operating stroke	20-70mm
Number of contacts	2NO 2NC	Insulation resistance	> 500m Ω
Response time	<2ms	Reset mode	automatic reset
Contact rating	AC380V 5A - DC24V 1A	Protection level	IP66

## INSTALLATION DIAGRAM

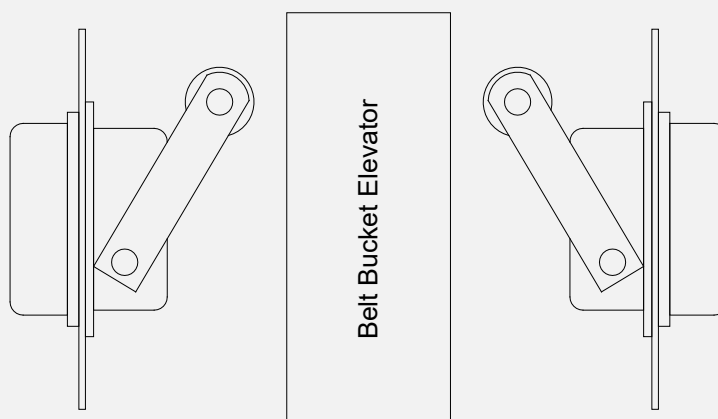

## WORKING PRINCIPLE

The Misalignment switch of the belt bucket elevators is installed on the upper, lower, left and right wallboards of the belt bucket elevators to detect the belt deviation. When installing, the distance between the roller and the glue is 20-70mm, which can be adjusted that determined by the user and Generally, it is subject to no friction to the roller. When the deviation occurs, the belt moves to the outside to the roller, and the roller drives the adjusting rod to make the deviation switch act to cut off the equipment.

## DIMENSION

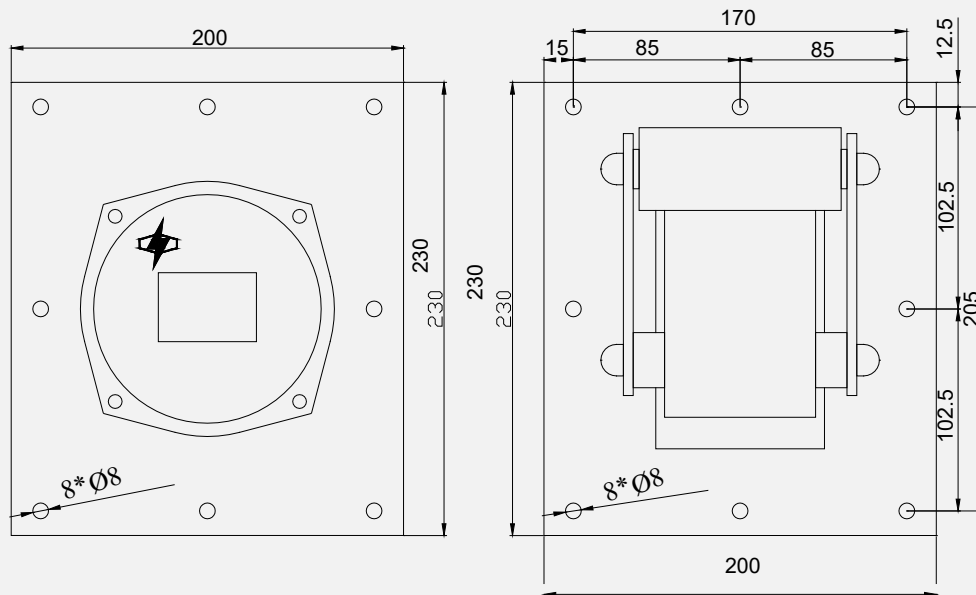

## INSTALLATION STEPS

- 1) Generally, a pair of Misalignment switch is installed on the side of the upper and lower casing entering the drum, which is about 1m away from the center of the upper and lower drums. It can also be installed in the middle casing close to the belt drum as required to prevent excessive swing of the belt running and the detection error of the deviation switch
- 2) When installing the Misalignment switch, the roller should follow the running direction of the belt
- 3) Adjust the installation distance of roller to allow belt offset generally 40-60mm
- 4) After installation, open the back cover, adjust the micro switch cam to enter the groove, cover the rear cover, and connect the wires

