



Conveyor Belt - Speed Switch

Model: IS-SPD



OVERVIEWS

The operation of the belt conveyor, the speed switch can judge whether there is a belt slip fault by detecting the belt speed, and send an alarm signal in time according to the change of speed, so as to avoid the expansion of losses and accidents. This product adopts advanced ARM processor technology and embedded control principle, with stable performance, powerful function and high protection level

CHARACTERISTIC

- Adopt high-strength Aluminum-alloy precise die-casting shell, with strong impact resistant capability
- The surface of the shell is sprayed with plastic and has strong corrosion resistance
- The shell has high protection level, good sealing, and can be used in harsh environment
- Using ARM MCU as control unit, it has fast response speed, high precision and small error
- Integral design, two bolts fixed, easy to install and use
- High contact capacity relay output

TECHNICAL DATA

Ambient temperature	-40°C~ 50°C	Working voltage	AC220V 50/60HZ
Relative humidity	0 ~ 95%	Detection range	10~9999 R/min
Atmospheric pressure	80 kPa ~110kPa	Alarm threshold value	Speed down by 50%
Power consumption	3W	Start delay	10 S (Default set)
Output mode and quantity	1×SPDT	Optimum detection distance of sensor head	10mm
Contact rating	AC380V 3A - DC24V 3A	Protection level	IP67

DIMENSION

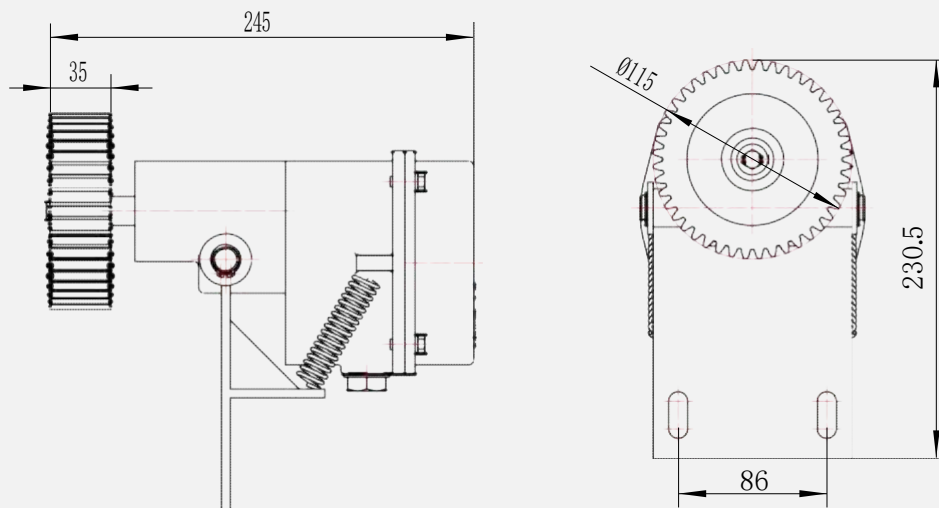

Units : mm

INSTALLATION DIAGRAM

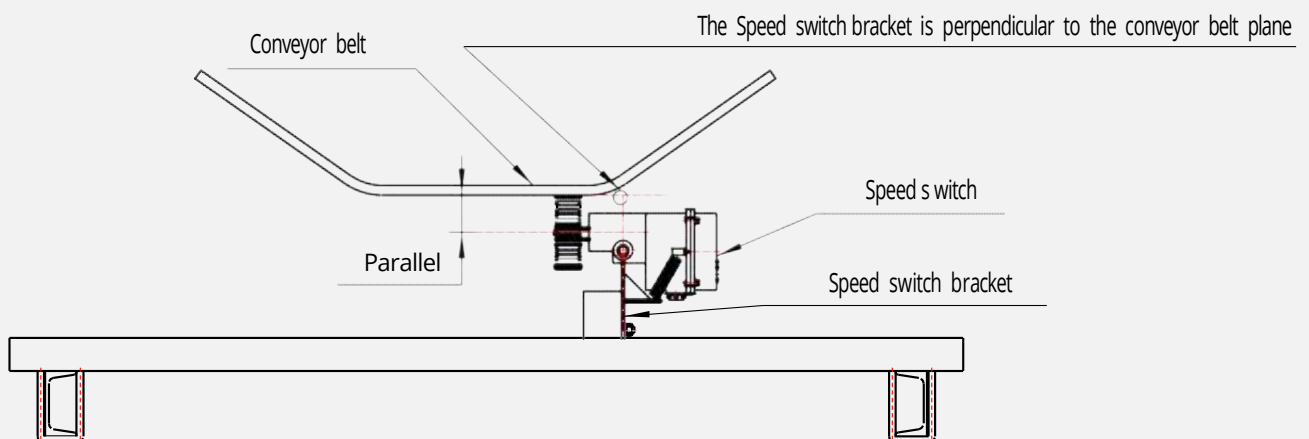

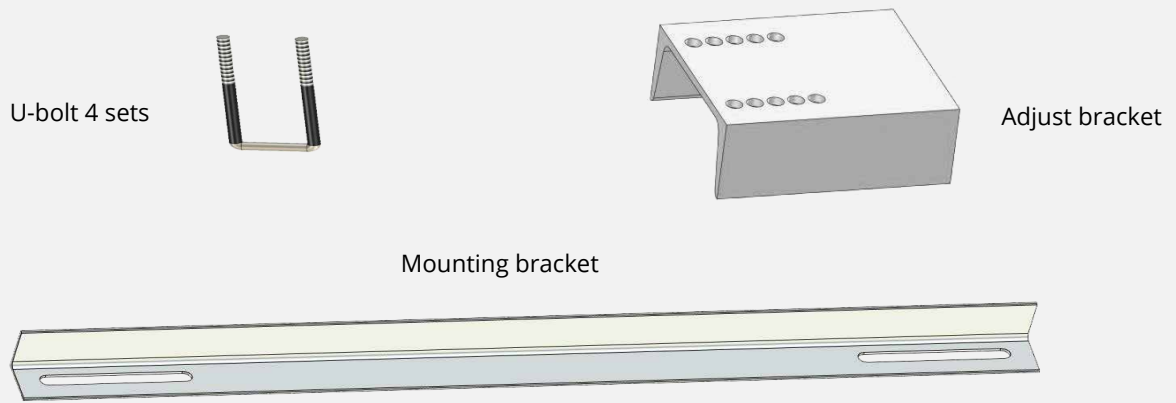

INSTALLATION STEPS

1) Assemble the mounting bracket, the welding position of adjust bracket is determined according to the position of speed switch. It should be installed at the place where the running is stable and the sinking of conveyor belt is small. It is necessary to ensure that the contact wheel and conveyor belt are in close contact

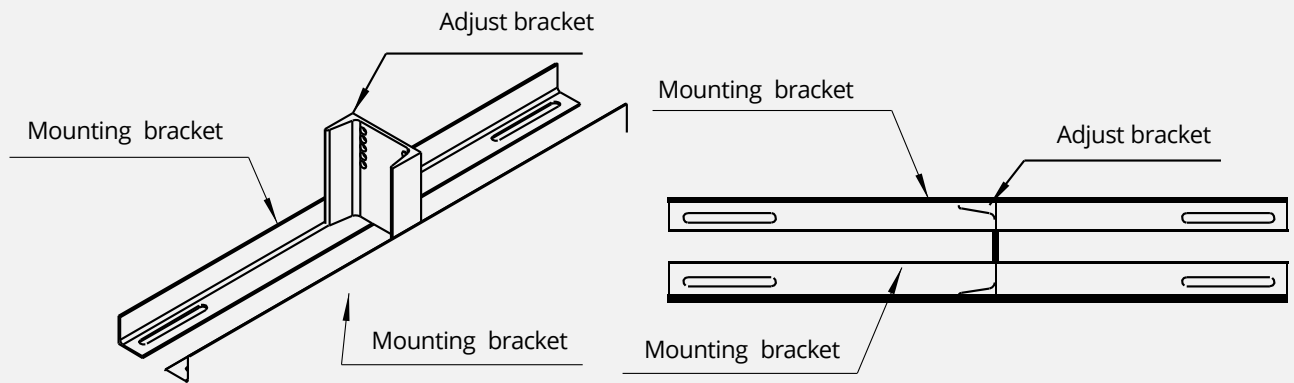

2) Install the assembled bracket on the conveyor frame with U-bolt.

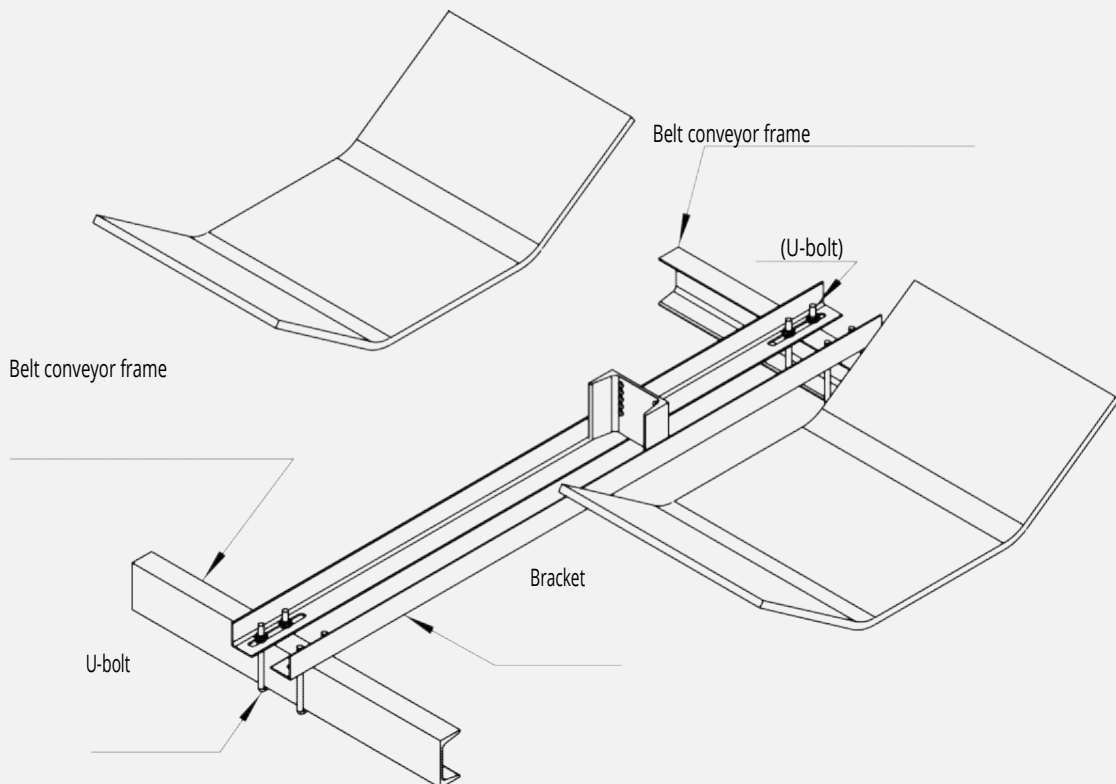

- 3) Install the speed switch on adjust bracket then fastening, guarantee the contact wheel axis parallel to the conveyor belt, The movement direction parallel with the conveyor belt operate direction, the user can configure mounting bracket according to the height of conveyor size, installation to ensure that the contact wheel and conveyor belt surface within the elastic range, namely, speed switch bracket and conveyor belt surface perpendicular

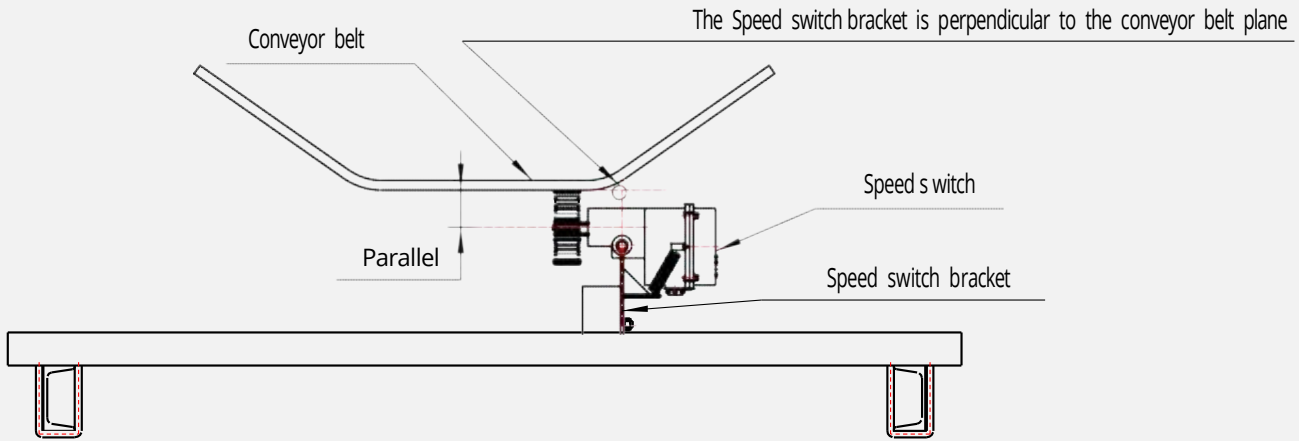

WIRING DIAGRAM

The speed switch leads out a six-core cable (red, yellow, black, blue, brown and white) in the outlet hole. Blue and brown are the input contacts of AC220V power supply, black and red are the normally open contacts (normally open when normally speed, closed when slip alarm), and black and yellow are normally closed contact (normally closed when normally speed, Disconnect when slip alarm). The white line is the ground line. If there are exceptions, please refer to the wiring principle diagram on the product

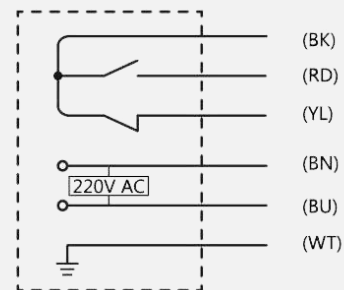

WORKING PRINCIPLE

Speed switch contact wheel closed contact with conveyor belt. When the conveyor belt is running, it drives the contact wheel to rotate, Thus the output pulse signal of the photoelectric sensor inside the device is entered into the counting unit, MCU to process judge after receiving signal, Real-time monitoring of the conveyor belt speed, when the conveyor belt speed down 50% compared with normal speed, output a switch signal, users can use this switch signal to realize stall stop in their own control network, to prevent the production accident caused by a conveyor belt slip

It does not need any setting and can be installed in any position of the belt conveyor. There is no violent wear between the contact wheel and the conveyor belt. It has fast response speed, high precision, small error and convenient installation and adjustment

